

XBee™/XBee-PRO™ OEM RF Modules

XBee/XBee-PRO OEM RF Modules
RF Module Operation
RF Module Configuration
Appendices



Product Manual v1.06

For OEM RF Module Part Numbers: XB24-...-001, XB24-...-002
XBP24-...-001, XBP24-...-002

ZigBee™/IEEE® 802.15.4 OEM RF Modules by MaxStream, Inc.



MaxStream®

355 South 520 West, Suite 180
Lindon, UT 84042
Phone: (801) 765-9885
Fax: (801) 765-9895

rf-xperts@maxstream.net
www.MaxStream.net (live chat support)

M100232
2005.12.13

© 2005 MaxStream, Inc. All rights reserved

No part of the contents of this manual may be transmitted or reproduced in any form or by any means without the written permission of MaxStream, Inc.

XBee™ and XBee-PRO™ are trademarks of MaxStream, Inc.

ZigBee™ is a registered trademark of the ZigBee Alliance.

Technical Support:

Phone: (801) 765-9885

Live Chat: www.maxstream.net

E-mail: rf-xperts@maxstream.net

Contents

1. XBee/XBee-PRO OEM RF Modules	4	Appendix A: Agency Certifications	22
1.1. Key Features	4	FCC Certification	22
1.1.1. Worldwide Acceptance	4	OEM Labeling Requirements	22
1.2. Specifications	5	FCC Notices	22
1.3. Mechanical Drawings	5	FCC-Approved Antennas (2.4 GHz)	23
1.4. Pin Signals	6	European Certification	24
1.5. Electrical Characteristics	6	OEM Labeling Requirements	24
2. RF Module Operation	7	Restrictions	24
2.1. Serial Communications	7	Declarations of Conformity	24
2.1.1. UART Data Flow	7	Appendix B: Development Guide	25
2.1.2. Flow Control	8	Development Kit Contents	25
2.2. Modes of Operation	9	Interfacing Options	25
2.2.1. Idle Mode	9	RS-232 Interface Board	26
2.2.2. Transmit & Receive Modes	9	Physical Interface	26
2.2.3. Sleep Mode	11	RS-232 Pin Signals	27
2.2.4. Command Mode	13	Wiring Diagrams	28
3. RF Module Configuration	14	Adapters	29
3.1. Programming the RF Module	14	USB Interface Board	30
3.1.1. Programming Examples	14	Physical Interface	30
3.2. Command Reference Tables	15	USB Pin Signals	30
3.2.1. Command Descriptions	16	Appendix C: Additional Information	31
		1-Year Warranty	31
		Ordering Information	31
		Contact MaxStream	32

1. XBee/XBee-PRO OEM RF Modules

XBee and XBee-PRO Modules were engineered to meet ZigBee/IEEE 802.15.4 standards and support the unique needs of low-cost, low-power wireless sensor networks. The modules require minimal power and provide reliable delivery of critical data between devices.

The modules operate within the ISM 2.4 GHz frequency band and are pin-for-pin compatible with each other.



1.1. Key Features

Long Range Data Integrity

XBee Range

- Indoor/Urban: up to 100' (30 m)
- Outdoor line-of-sight: up to 300' (100 m)
- Transmit Power: 1 mW (0 dBm)
- Receiver Sensitivity: -92 dBm

XBee-PRO Range

- Indoor/Urban: up to 300' (100 m)
- Outdoor line-of-sight: up to 1 mile (1500 m)
- Transmit Power: 100 mW (20 dBm) EIRP
- Receiver Sensitivity: -100 dBm

RF Data Rate: 250,000 bps

Advanced Networking & Security

Retries and Acknowledgements

DSSS (Direct Sequence Spread Spectrum)

Each direct sequence channels has over 65,000 unique network addresses available

Point-to-point, point-to-multipoint and peer-to-peer topologies supported

128-bit Encryption (downloadable firmware version coming soon)

Self-routing/Self-healing mesh networking (downloadable firmware version coming soon)

Low Power

XBee

- TX Current: 45 mA (@3.3 V)
- RX Current: 50 mA (@3.3 V)
- Power-down Current: < 10 μ A

XBee-PRO

- TX Current: 270 mA (@3.3 V)
- RX Current: 55 mA (@3.3 V)
- Power-down Current: < 10 μ A

Easy-to-Use

No configuration necessary for out-of box RF communications

Free X-CTU Software (Testing and configuration software)

AT Command Mode for simple configuration of module parameters

Small form factor

Network compatible with other ZigBee/802.15.4 devices

Free & Unlimited Technical Support

1.1.1. Worldwide Acceptance

FCC Approval (USA) Refer to Appendix A [p22] for FCC Requirements.

Systems that include XBee/XBee-PRO Modules inherit MaxStream's Certifications.

ISM (Industrial, Scientific & Medical) 2.4 GHz frequency band

Manufactured under **ISO 9001:2000** registered standards

XBee/XBee-PRO RF Modules are optimized for use in **US, Canada, Australia, Israel and Europe** (contact MaxStream for complete list of approvals).



1.2. Specifications

Table 1-01. Specifications of the XBee/XBee-PRO OEM RF Modules

Specification	XBee	XBee-PRO
Performance		
Indoor/Urban Range	up to 100 ft. (30 m)	Up to 300' (100 m)
Outdoor RF line-of-sight Range	up to 300 ft. (100 m)	Up to 1 mile (1500 m)
Transmit Power Output	1mW (0 dBm)	60 mW (18 dBm) conducted, 100 mW (20 dBm) EIRP*
RF Data Rate	250,000 bps	250,000 bps
Interface Data Rate (software selectable)	1200 - 115200 bps (non-standard baud rates also supported)	1200 - 115200 bps (non-standard baud rates also supported)
Receiver Sensitivity	-92 dBm (1% packet error rate)	-100 dBm (1% packet error rate)
Power Requirements		
Supply Voltage	2.8 – 3.4 V	2.8 – 3.4 V
Transmit Current (typical)	45 mA (@ 3.3 V)	270 mA (@ 3.3 V)
Receive Current (typical)	50 mA (@ 3.3 V)	55 mA (@ 3.3 V)
Power-down Current	< 10 µA	< 10 µA
General		
Operating Frequency	ISM 2.4 GHz	ISM 2.4 GHz
Dimensions	0.960" x 1.087" (2.438cm x 2.761cm)	0.960" x 1.297" (2.438cm x 3.294cm)
Operating Temperature	-40 to 85° C (industrial)	-40 to 85° C (industrial)
Antenna Options	U.FL Connector, Chip Antenna or Whip Antenna	U.FL Connector, Chip Antenna or Whip Antenna
Networking & Security		
Supported Network Topologies	Point-to-Point, Point-to-Multipoint, Peer-to-Peer and Mesh (coming soon)	Point-to-Point, Point-to-Multipoint, Peer-to-Peer and Mesh (coming soon)
Number of Channels (software selectable)	16 Direct Sequence Channels	13 Direct Sequence Channels
Filtration Options	PAN ID, Channel and Source/Destination Addresses	PAN ID, Channel and Source/Destination Addresses
Agency Approvals		
FCC Part 15.247	OUR-XBEE	OUR-XBEEPRO
Industry Canada (IC)	4214A XBEE	4214A XBEEPRO
Europe	ETSI	ETSI (Max. 10 mW transmit power output)*

* When operating in Europe: XBee-PRO Modules must be configured to operate at a maximum transmit power output level of 10 dBm. The power output level is set using the PL command. The PL parameter must equal "0" (10 dBm).

Additionally, European regulations stipulate an EIRP power maximum of 12.86 dBm (19 mW) for the XBee-PRO and 12.11 dBm for the XBee when integrating high-gain antennas.

1.3. Mechanical Drawings

Figure 1-01. Mechanical drawings of the XBee/XBee-PRO OEM RF Modules (antenna options not shown)

XBee and XBee-PRO RF Modules are pin-for-pin compatible.

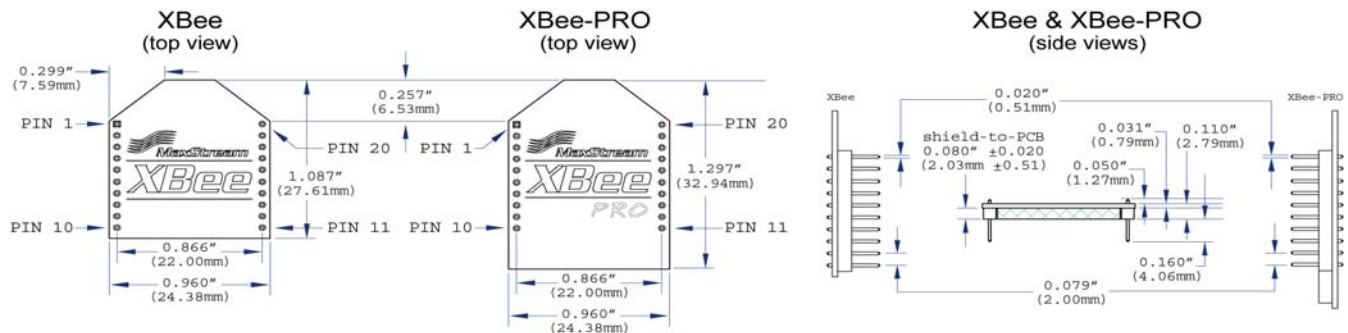

1.4. Pin Signals

Figure 1-02. XBee/XBee-PRO RF Module Pin Number
(top sides shown - shields on bottom)

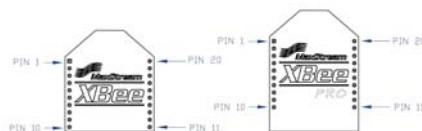

Table 1-02. Pin Assignments for the XBee and XBee-PRO Modules
(Low-asserted signals are distinguished with a horizontal line above signal name.)

Pin #	Name	Direction	Description
1	VCC	-	Power supply
2	DOUT	Output	UART Data Out
3	DIN / CONFIG	Input	UART Data In
4	CD* / DOUT_EN* / DO8*	Output	Carrier Detect, TX_enable or Digital Output 8
5	RESET	Input	Module Reset
6	PWM0 / RSSI	Output	PWM Output 0 or RX Signal Strength Indicator
7	[reserved]	-	Do not connect
8	[reserved]	-	Do not connect
9	DTR / SLEEP_RQ / DI8	Input	Pin Sleep Control Line or Digital Input 8
10	GND	-	Ground
11	RF_TX* / AD4* / DIO4*	Either	Transmission Indicator, Analog Input 4 or Digital I/O 4
12	CTS* / DIO7*	Either	Clear-to-Send Flow Control or Digital I/O 7
13	ON / SLEEP	Output	Module Status Indicator
14	VREF*	Input	Voltage Reference for A/D Inputs
15	Associate / AD5* / DIO5*	Either	Associated Indicator, Analog Input 5 or Digital I/O 5
16	RTS* / AD6* / DIO6*	Either	Request-to-Send Flow Control, Analog Input 6 or Digital I/O 6
17	COORD_SEL* / AD3* / DIO3*	Either	Analog Input 3, Digital I/O 3 or Coordinator Select
18	AD2* / DIO2*	Either	Analog Input 2 or Digital I/O 2
19	AD1* / DIO1*	Either	Analog Input 1 or Digital I/O 1
20	AD0* / DIO0*	Either	Analog Input 0 or Digital I/O 0

* Functions not supported at the time of this release.

Design Notes:

- Minimum connections are: VCC, GND, DOUT and DIN
- Signal Direction is specified with respect to the module
- Module includes a 50k pull-up resistor attached to RESET
- Unused pins should be left disconnected.

1.5. Electrical Characteristics

Table 1-03. DC Characteristics of the XBee & XBee-PRO (VCC = 2.8 - 3.4 VDC)

Symbol	Parameter	Condition	Min	Typical	Max	Units
V _{IL}	Input Low Voltage	All Digital Inputs	-	-	0.35 * VCC	V
V _{IH}	Input High Voltage	All Digital Inputs	0.7 * VCC	-	-	V
V _{OL}	Output Low Voltage	I _{OL} = 2 mA, VCC >= 2.7 V	-	-	0.5	V
V _{OH}	Output High Voltage	I _{OH} = -2 mA, VCC >= 2.7 V	VCC - 0.5	-	-	V
I _{IN}	Input Leakage Current	V _{IN} = VCC or GND, all inputs, per pin	-	0.025	1	uA
I _{OZ}	High Impedance Leakage Current	V _{IN} = VCC or GND, all I/O High-Z, per pin	-	0.025	1	uA
TX	Transmit Current	VCC = 3.3 V	-	45 (XBee) / 270 (PRO)	-	mA
RX	Receive Current	VCC = 3.3 V	-	50 (XBee) / 55 (PRO)	-	mA
PWR-DWN	Power-down Current	SM parameter = 1	-	< 10	-	uA

2. RF Module Operation

2.1. Serial Communications

The XBee/XBee-PRO OEM RF Modules interface to a host device through a logic-level asynchronous serial port. Through its serial port, the module can communicate with any logic and voltage compatible UART; or through a level translator to any serial device (For example: RS-232/485/422 or USB interface board).

2.1.1. UART Data Flow

Devices that have a UART interface can connect directly to the pins of the RF module as shown in the figure below.

Figure 2-01. Figure 2-01.System Data Flow Diagram in a UART-interfaced environment
(Low-asserted signals distinguished with horizontal line over signal name.)

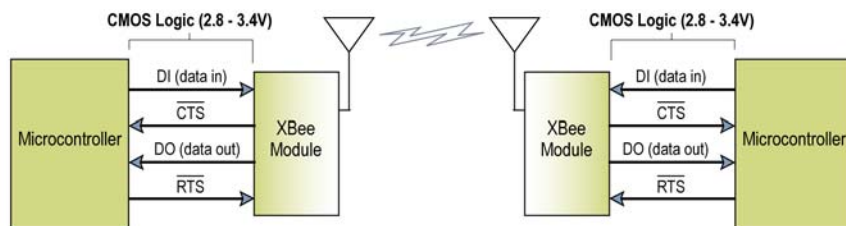

Serial Data

Data enters the module UART through the DI pin (pin 3) as an asynchronous serial signal. The signal should idle high when no data is being transmitted.

Each data byte consists of a start bit (low), 8 data bits (least significant bit first) and a stop bit (high). The following figure illustrates the serial bit pattern of data passing through the module.

Figure 2-02. UART data packet 0x1F (decimal number "31") as transmitted through the RF module
Example Data Format is 8-N-1 (bits - parity - # of stop bits)

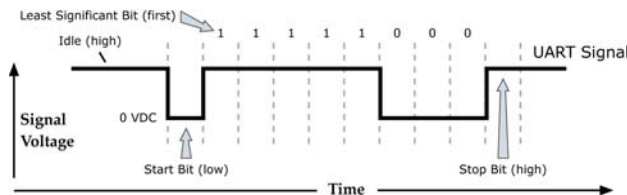

The module UART performs tasks, such as timing and parity checking, that are needed for data communications. Serial communications depend on the two UARTs to be configured with compatible settings (baud rate, parity, start bits, stop bits, data bits)

Both the module and host (PC) settings can be viewed and adjusted using MaxStream's proprietary X-CTU Software. Use the "PC Settings" tab to configure host settings. Use the "Terminal" or "RF Module Configuration" tab to configure the module settings.

NOTE: Failure to enter AT Command Mode is most commonly due to baud rate mismatch. Ensure the 'Baud' setting on the "PC Settings" tab matches the interface data rate of the RF module (by default, BD parameter = 3 (which is associated to 9600 bps)).

2.1.2. Flow Control

Figure 2-03. Internal Data Flow Diagram

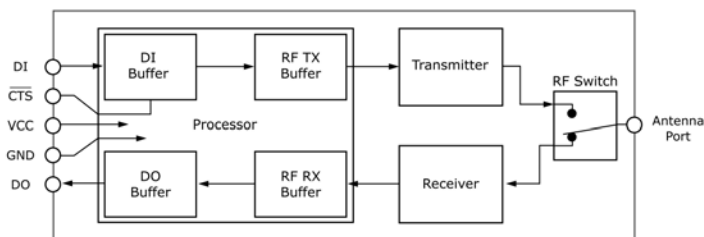

DI (Data In) Buffer

When serial data enters the RF module through the DI pin (pin 3), the data is stored in the DI Buffer until it can be processed.

Hardware Flow Control ($\overline{\text{CTS}}$). When the DI buffer is 17 bytes away from being full; by default, the module de-asserts $\overline{\text{CTS}}$ (high) to signal to the host device to stop sending data [refer to D7 (DIO7 Configuration) parameter]. $\overline{\text{CTS}}$ is re-asserted after the DI Buffer has 34 bytes of memory available.

How to eliminate the need for flow control:

1. Send messages that are smaller than the DI buffer size.
2. Interface at a lower baud rate [BD (Interface Data Rate) parameter] than the throughput data rate.

Case in which the DI Buffer may become full and possibly overflow:

If the module is receiving a continuous stream of RF data, any serial data that arrives on the DI pin is placed in the DI Buffer. The data in the DI buffer will be transmitted over-the-air when the module is no longer receiving RF data in the network.

NOTE: $\overline{\text{CTS}}$ hardware flow control is not supported in this release (v1.06). Contact MaxStream support to download firmware that supports this function.

DO (Data Out) Buffer

When RF data is received, the data enters the DO buffer and is sent out the serial port to a host device. Once the DO Buffer reaches capacity, any additional incoming RF data is lost.

Hardware Flow Control ($\overline{\text{RTS}}$). If $\overline{\text{RTS}}$ is enabled for flow control (D6 (DIO6 Configuration) Parameter = 1), data will not be sent out the DO Buffer as long as $\overline{\text{RTS}}$ (pin 16) is de-asserted.

Two cases in which the DO Buffer may become full and possibly overflow:

1. If the RF data rate is set higher than the interface data rate of the module, the module will receive data from the transmitting module faster than it can send the data to the host.
2. If the host does not allow the module to transmit data out from the DO buffer because of being held off by hardware or software flow control.

NOTE: $\overline{\text{RTS}}$ hardware flow control is not supported in this release (v1.06). Contact MaxStream support to download firmware that supports this function.

2.2. Modes of Operation

XBee/XBee-PRO RF Modules operate in five modes.

Figure 2-04. XBee/XBee-PRO RF Module Modes of Operation

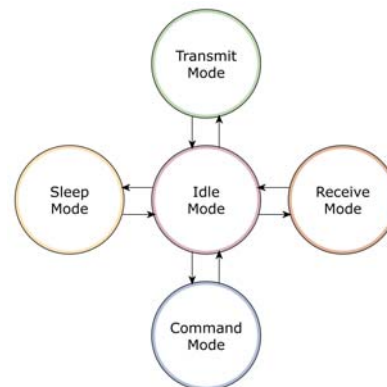

2.2.1. Idle Mode

When not receiving or transmitting data, the RF module is in Idle Mode. The RF module shifts into the other modes of operation under the following conditions:

- Transmit Mode (Serial data is received in the DI Buffer)
- Receive Mode (Valid RF data is received through the antenna)
- Sleep Mode (Sleep Mode condition is met)
- Command Mode (Command Mode Sequence is issued)

2.2.2. Transmit & Receive Modes

Addressing

When communication occurs between two networked devices, each data packet contains a <Source Address> and a <Destination Address> field. The XBee/XBee-PRO RF Module conforms to the 802.15.4 specification and supports both short 16-bit addresses and long 64-bit addresses. A unique 64-bit IEEE source address is assigned at the factory and can be read with the SL (Serial Number Low) and SH (Serial Number High) parameters. Short addressing must be configured manually. An RF module will use its unique 64-bit address as its Source Address if its MY value is "0xFFFF" or "0xFFFE".

To send a packet to a specific RF module using 64-bit addressing, set the Destination Address (DL + DH) to match the Source Address (SL + SH) of the intended destination RF module. To send a packet to a specific RF module using 16-bit addressing, set the DL (Destination Address Low) parameter to the MY (Source Address) parameter and set the DH (Destination Address High) parameter to "0".

Unicast Mode

Unicast Mode enables acknowledged communications. While in this mode, receiving modules send an ACK (acknowledgement) of RF packet reception to the transmitter. If the transmitting module does not receive the ACK, the transmitter will re-send the packet up to three times until the ACK is received.

Unicast Mode is the only mode that supports retries.

Short 16-bit addresses. The module can be configured to use short 16-bit addresses as the Source Address by setting (MY < 0xFFFE). Setting the DH parameter (DH = 0) will configure the Destination Address to be a short 16-bit address (if DL < 0xFFFE). For two modules to communicate using short addressing, the Destination Address of the transmitter module must match the MY parameter of the receiver.

The following table shows a sample network configuration that would enable Unicast Mode communications using 16-bit short addresses.

Table 2-01. Sample Unicast Configuration (using 16-bit addressing)

Parameter	RF Module 1	RF Module 2
MY (Source Address)	0x01	0x02
DH (Destination Address High)	0	0
DL (Destination Address Low)	0x02	0x01

Long 64-bit addresses. The RF module’s serial number (SL parameter concatenated to the SH parameter) can be used as a 64-bit source address when the MY (16-bit Source Address) parameter is disabled. When the MY parameter is disabled (set MY = 0xFFFF or 0xFFFE), the module’s source address is set to the 64-bit IEEE address stored in the SH and SL parameters.

When an End Device associates to a Coordinator, its MY parameter is set to 0xFFFE to enable 64-bit addressing. The 64-bit address of the module is stored as SH and SL parameters. To send a packet to a specific module, the Destination Address (DL + DH) on one module must match the Source Address (SL + SH) of the other.

Broadcast Mode

Any RF module will accept a packet that contains a broadcast address. When configured to operate in Broadcast Mode, receiving modules do not send ACKs (Acknowledgements) and transmitting RF modules do not automatically re-send packets as is the case in Unicast Mode.

To send a broadcast packet to all modules regardless of 16-bit or 64-bit addressing, set destination addresses of all the modules as shown below.

Sample Configuration (All modules in the network):

- DL (Destination Low Address) = 0x0000FFFF
- DH (Destination High Address) = 0x00000000

NOTE: When programming the module, parameters are entered in hexadecimal notation (without the “0x” prefix). Leading zeros may be omitted.

Direct vs. Indirect Transmission

There are two methods to transmit data. The first method, Direct Transmission, transmits data immediately to the <Destination Address>. The second method, Indirect Transmission, retains a packet for a period of time and transmits the data only after the destination module (<RF Module Source Address> = <Data Destination Address>) requests the data. Indirect Transmissions can only occur on a Coordinator. Thus, if all devices in a network are End Devices, only Direct Transmissions will occur. Indirect Transmissions are useful to ensure packet delivery to a sleeping device. The Coordinator currently is able to retain up to 2 indirect messages.

2.2.3. Sleep Mode

Sleep Modes enable the RF module to enter states of low-power consumption when not in use. In order to enter Sleep Mode, one of the following conditions must be met (in addition to the module having a non-zero SM parameter value):

- Sleep_RQ (pin 9) is asserted.
- The module is idle (no data transmission or reception) for the amount of time defined by the ST (Time before Sleep) parameter. [NOTE: ST is only active when SM = 4-6]

Table 2-02. Sleep Mode Configurations

Sleep Mode Setting	Transition into Sleep Mode	Transition out of Sleep Mode (wake)	Characteristics	Related Commands	Power Consumption
Pin Hibernate (SM = 1)	Assert (high) Sleep_RQ (pin 9)	De-assert (low) Sleep_RQ	Pin/Host-controlled	(SM)	< 10 μ A (@3.0 VCC)
Pin Doze (SM = 2)	Assert (high) Sleep_RQ (pin 9)	De-assert (low) Sleep_RQ	Pin/Host-controlled	(SM)	< 50 μ A
Cyclic Sleep (SM = 4 - 6)	Automatic transition to Sleep Mode as defined by the SM (Sleep Mode) and ST (Time before Sleep) parameters.	Transition occurs after the cyclic sleep time interval elapses. The time interval is defined by the SP (Cyclic Sleep Period) parameter.	RF Module wakes in pre-determined time intervals to detect if RF data is present.	(SM), SP, ST	< 50 μ A

The SM command is central to setting Sleep Mode configurations. By default, Sleep Modes are disabled (SM = 0) and the module remains in Idle/Receive Mode. When in this state, the module is constantly ready to respond to serial or RF activity.

Pin/Host-controlled Sleep Modes

Pin Hibernate (SM = 1)

- Pin/Host-controlled
- Typical power-down current: < 10 μ A (@3.0 VCC)
- Wake-up time: 13.2 msec

Pin Hibernate Mode minimizes quiescent power (power consumed when in a state of rest or inactivity). This mode is voltage level-activated; when Sleep_RQ is asserted, the module will finish any transmit or receive activities, enter Idle Mode and then enter a state of sleep. The module will not respond to either serial or RF activity while in pin sleep.

To wake a sleeping module operating in Pin Hibernate Mode, de-assert Sleep_RQ (pin 9). The module will wake when Sleep_RQ is de-asserted and is ready to transmit or receive when the $\overline{\text{CTS}}$ line is low. When waking the module, the pin must be de-asserted at least two 'byte times' after $\overline{\text{CTS}}$ goes low. This assures that there is time for the data to enter the DI buffer.

Pin Doze (SM = 2)

- Pin/Host-controlled
- Typical power-down current: < 50 μ A
- Wake-up time: 2 msec

Pin Doze Mode functions as does Pin Hibernate Mode; however, Pin Doze features faster wake-up time and higher power consumption. This mode is voltage level-activated; when Sleep_RQ is asserted, the module will finish any transmit or receive activities, enter Idle Mode and then enter a state of sleep. The module will not respond to either serial or RF activity while in pin sleep.

To wake a sleeping module operating in Pin Doze Mode, de-assert Sleep_RQ (pin 9). The module will wake when Sleep_RQ is de-asserted and is ready to transmit or receive when the $\overline{\text{CTS}}$ line is low. When waking the module, the pin must be de-asserted at least two 'byte times' after $\overline{\text{CTS}}$ goes low. This assures that there is time for the data to enter the DI buffer.

Cyclic Sleep Modes

Cyclic Sleep Remote (SM = 4)

- Typical Power-down Current: < 50 μ A (when asleep)
- Wake-up time: 2 msec

The Cyclic Sleep Modes allow modules to periodically check for RF data. When the SM parameter is set to '4', the module is configured to sleep, then wakes once a cycle to check for data from a module configured as a Cyclic Sleep Coordinator (SM = 6). The Cyclic Sleep Remote sends a poll request to the coordinator at a specific interval set by the SP (Cyclic Sleep Period) parameter. The coordinator will transmit any queued data addressed to that specific remote upon receiving the poll request.

If no data is queued for the remote, the coordinator will not transmit and the remote will return to sleep for another cycle. If queued data is transmitted back to the remote, it will stay awake to allow for back and forth communication until the ST (Time before Sleep) timer expires.

Also note that $\overline{\text{CTS}}$ will go low each time the remote wakes, allowing for communication initiated by the remote host if desired.

Cyclic Sleep Remote with Pin Wake-up (SM = 5)

Use this mode to wake a sleeping remote module through either the RF interface or by the de-assertion of Sleep_RQ for event-driven communications. The cyclic sleep mode works as described above (Cyclic Sleep Remote) with the addition of a pin-controlled wake-up at the remote module. The Sleep_RQ pin is edge-triggered, not level-triggered. The module will wake when a low is detected then set $\overline{\text{CTS}}$ low as soon as it is ready to transmit or receive.

Any activity will reset the ST (Time before Sleep) timer so the module will go back to sleep only after there is no activity for the duration of the timer. Once the module wakes (pin-controlled), further pin activity is ignored. The module transitions back into sleep according to the ST time regardless of the state of the pin.

Cyclic Sleep Coordinator (SM = 6)

- Typical current = Receive current
- Always awake

Use this mode to configure a module to wake cyclic sleeping remotes through the RF interface. The cyclic sleep coordinator will accept a message addressed to a specific remote 16 or 64-bit address and hold it in a buffer until the remote wakes and sends a poll to request the message. Messages not sent directly (buffered and requested) are called "Indirect messages". The coordinator will only queue one indirect message at a time. The coordinator will hold the indirect message for a period 2.5 times the sleeping period indicated by the SP (Cyclic Sleep Period) parameter. The coordinator's SP parameter should be set to match the value used by the remotes.

The ST parameters of the coordinator and remotes should be set to the same value because the coordinator will track the 'awake' period of the recent 10 remotes to wake. If the coordinator receives additional messages addressed to a remote that should be awake, the coordinator will send a direct message to that remote instead of queuing it. The coordinator is always awake so that any remote unit can transmit either a poll request or a data message at any time.

2.2.4. Command Mode

To modify or read RF Module parameters, the module must first enter into Command Mode - a state in which incoming characters are interpreted as commands. Two command modes are supported: AT Command Mode and AT+ Command Mode.

A robust set of AT Commands is available for programming and customizing the module.

AT Command Mode

To Enter AT Command Mode:

Send the 3-character command sequence “+++” and observe guard times before and after the command characters. [Refer to the “Default AT Command Mode Sequence” below.]

Default AT Command Mode Sequence (for transition to Command Mode):

- No characters sent for one second [GT (Guard Times) parameter = 0x3E8]
- Input three plus characters (“+++”) within one second [CC (Command Sequence Character) parameter = 0x2B.]
- No characters sent for one second [GT (Guard Times) parameter = 0x3E8]

All of the parameter values in the sequence can be modified to reflect user preferences.

To Send AT Commands:

Send AT commands and parameters using the syntax shown below.

Figure 2-05. Syntax for sending AT Commands

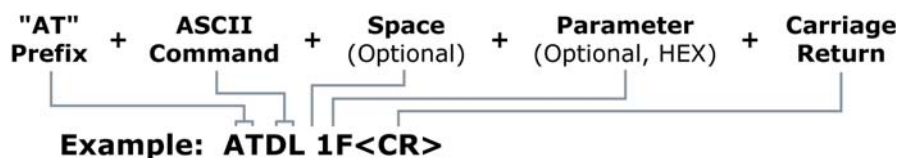

To read a parameter value stored in the RF module’s register, leave the parameter field blank.

The preceding example would change the RF module Destination Address (Low) to “0x1F”. To store the new value to non-volatile (long term) memory, subsequently send the WR (Write) command.

For modified parameter values to persist in the module’s registry, changes must be saved to non-volatile memory using the WR (Write) Command. Otherwise, parameters are restored to previously saved values after the module is powered off and then on again (or re-booted).

System Response. When a command is sent to the RF module, the module will parse and execute the command. Upon successful execution of a command, the module returns an “OK” message. If execution of a command results in an error, the module returns an “ERROR” message.

To Exit AT Command Mode:

1. Send ATCN (Exit Command Mode) Command.
[OR]
2. If no valid AT Commands are received within the time specified by CT (Command Mode Timeout) Command, the RF module automatically returns to Idle Mode.

For an example of programming the RF module using AT Commands and descriptions of each configurable parameter, refer to the “RF Module Configuration” chapter [p14].

3. RF Module Configuration

3.1. Programming the RF Module

Refer to the “Command Mode” section [p13] for more information about entering Command Mode, sending AT commands and exiting Command Mode.

3.1.1. Programming Examples

Setup

The programming examples in this section require the installation of MaxStream's X-CTU Software and a serial connection to a PC. (MaxStream stocks RS-232 and USB boards to facilitate interfacing to a PC.)

1. Install MaxStream's X-CTU Software to a PC by double-clicking the "setup_X-CTU.exe" file. (The file is located on the MaxStream CD and under the 'Software' section of the following web page: www.maxstream.net/helpdesk/download.php)
2. Mount the RF module to an interface board, then connect the module assembly to a PC.
3. Launch the X-CTU Software and select the 'PC Settings' tab. Verify the baud and parity settings of the Com Port match those of the RF module.

NOTE: Failure to enter AT Command Mode is most commonly due to baud rate mismatch. Ensure the 'Baud' setting on the 'PC Settings' tab matches the interface data rate of the RF module (by default, BD parameter = 3 (which corresponds to 9600 bps)).

Sample Configuration: Modify RF Module Destination Address

Example: Utilize the 'Terminal' tab of the X-CTU Software to change the RF module's DL (Destination Address Low) parameter and save the new address to non-volatile memory.

After establishing a serial connection between the RF module and a PC [refer to the 'Setup' section above], select the 'Terminal' tab of the X-CTU Software and enter the following command lines ('CR' stands for carriage return):

Method 1 (One line per command)

Send AT Command	System Response
+++	OK <CR> (Enter into Command Mode)
ATDL <Enter>	{current value} <CR> (Read Destination Address Low)
ATDL1AOD <Enter>	OK <CR> (Modify Destination Address Low)
ATWR <Enter>	OK <CR> (Write to non-volatile memory)
ATCN <Enter>	OK <CR> (Exit Command Mode)

Method 2 (Multiple commands on one line)

Send AT Command	System Response
+++	OK <CR> (Enter into Command Mode)
ATDL <Enter>	{current value} <CR> (Read Destination Address Low)
ATDL1AOD,WR,CN <Enter>	OK <CR> (Execute commands)

Sample Configuration: Restore RF Module Defaults

Example: Utilize the 'Modem Configuration' tab of the X-CTU Software to restore default parameter values of the RF module.

After establishing a connection between the RF module and a PC [refer to the 'Setup' section above], select the 'Modem Configuration' tab of the X-CTU Software.

1. Select the 'Read' button.
2. Select the 'Restore' button.

3.2. Command Reference Tables

Table 3-01. XBee/XBee-PRO Commands (RF modules expect numerical values in hexadecimal. Hexadecimal values are designated by the “0x” prefix. Decimal equivalents are designated by the “d” suffix.)

AT Command	Command Category	Name and Description	Parameter Range	Default
BD	Serial Interfacing	Interface Data Rate. Set/Read the serial interface data rate for communications between the RF module serial port and host.	0 - 7 (custom rates also supported)	3
CC	AT Command Mode Options	Command Sequence Character. Set/Read the ASCII character value to be used between Guard Times of the AT Command Mode Sequence (GT+CC+GT). The AT Command Mode Sequence enters the RF module to AT Command Mode.	0 - 0xFF	0x2B (‘+’ ASCII)
CH	Networking & Security	Channel. Set/Read the channel number used for transmitting and receiving between RF modules. Uses 802.15.4 protocol channel numbers.	0x0B - 0x1A (XBee) 0x0C - 0x18 (XBee-PRO)	0x0C (12d)
CN	AT Command Mode Options	Exit Command Mode. Explicitly exit AT Command Mode.	-	-
CT	AT Command Mode Options	Command Mode Timeout. Set/Read the period of inactivity (no valid commands received) after which the RF module automatically exits AT Command Mode and returns to Idle Mode.	2 - 0xFFFF [x 100 ms]	0x64 (100d)
DB	Diagnostics	Received Signal Strength. Read signal level [in dB] of last good packet received (RSSI). Absolute value is reported. (For example: 0x58 = -88 dBm) Reported value is accurate between -40 dBm and RX sensitivity.	0 - 0x64 [read-only]	-
DH	Networking & Security	Destination Address High. Set/Read the upper 32 bits of the 64-bit destination address. When combined with DL, it defines the destination address used for transmission. To transmit using a 16-bit address, set DH parameter to zero and DL less than 0xFFFF. 0x000000000000FFFF is the broadcast address for the PAN.	0 - 0xFFFFFFFF	0
DL	Networking & Security	Destination Address Low. Set/Read the lower 32 bits of the 64-bit destination address. When combined with DH, DL defines the destination address used for transmission. To transmit using a 16-bit address, set DH parameter to zero and DL less than 0xFFFF. 0x000000000000FFFF is the broadcast address for the PAN.	0 - 0xFFFFFFFF	0
GT	AT Command Mode Options	Guard Times. Set required period of silence before and after the Command Sequence Characters of the AT Command Mode Sequence (GT+ CC + GT). The period of silence is used to prevent inadvertent entrance into AT Command Mode.	0x02 - 0xFFFF [x 1 ms]	0x3E8 (1000d)
ID	Networking & Security	PAN ID. Set/Read the PAN (Personal Area Network) ID. 0xFFFF indicates a message for all PANs.	0xFFFF	0x3332 (13106d)
MY	Networking & Security	16-bit Source Address. Set/Read the RF module 16-bit source address. Set MY = 0xFFFF to disable reception of packets with 16-bit addresses. 64-bit source address (serial number) and broadcast address (0x000000000000FFFF) is always enabled.	0 - 0xFFFF	0
P0	Diagnostics	PWM0 Configurations. Select/Read function for PWM0.	0 - 1	1
PL	RF Interfacing	Power Level. Select/Read power level at which the RF module transmits.	0 - 4	4
RE	(Special)	Restore Defaults. Restore RF module parameters to factory defaults. Follow with WR command to save values to non-volatile memory.	-	-
RN	Networking & Security	Random Delay Slots. Set/Read the minimum value of the back-off exponent in the CSMA-CA algorithm that is used for collision avoidance. If RN = 0, collision avoidance is disabled during the first iteration of the algorithm (802.15.4 - macMinBE).	0 - 3	0
RO	Serial Interfacing	Packetization Timeout. Set/Read number of character times of inter-character delay required before transmission. Set to zero to transmit characters as they arrive instead of buffering them into one RF packet.	0 - 0xFF [x character times]	3
RP	Diagnostics	RSSI PWM Timer. Enable a PWM (pulse width modulation) output (on pin 3 of the RF modules) which shows RX signal strength.	0 - 0xFF [x 100 ms]	0x28 (40d)
SH	Diagnostics	Serial Number High. Read high 32 bits of the RF module's unique IEEE 64-bit address. 64-bit source address is always enabled.	0 - 0xFFFFFFFF [read-only]	Factory-set
SL	Diagnostics	Serial Number Low. Read low 32 bits of the RF module's unique IEEE 64-bit address. 64-bit source address is always enabled.	0 - 0xFFFFFFFF [read-only]	Factory-set
SM	Sleep (Low Power)	Sleep Mode. Set/Read Sleep Mode configurations.	0 - 6	0
SP	Sleep (Low Power)	Cyclic Sleep Period. Set/Read sleep period for cyclic sleeping remotes. Maximum sleep period is 268 seconds (0x68B0).	0x01 - 0x68B0 [x 10 ms]	0x64 (100d)
ST	Sleep (Low Power)	Time before Sleep. Set/Read time period of inactivity (no serial or RF data is sent or received) before activating Sleep Mode. The ST parameter is only valid with Cyclic Sleep settings (SM = 4 - 6). Set ST on Cyclic Sleep Coordinator to match Cyclic Sleep Remotes.	0x01 - 0xFFFF [x 1 ms]	0x1388 (5000d)
VR	Diagnostics	Firmware Version. Read firmware version of the RF module.	0 - 0xFFFF [read-only]	Factory-set
WR	(Special)	Write. Write parameter values to RF module's non-volatile memory so that modifications persist through subsequent power-up or reset.	-	-

3.2.1. Command Descriptions

Command descriptions in this section are listed alphabetically. Command categories are designated within "< >" symbols that follow each command title. XBee-PRO RF modules expect parameter values in hexadecimal (designated by the "0x" prefix).

BD (Interface Data Rate) Command

<Serial Interfacing> The BD command is used to set and read the serial interface data rate (baud rate) used between the RF modem and host. This parameter determines the rate at which serial data is sent to the RF modem from the host. Modified interface data rates do not take effect until the CN (Exit AT Command Mode) command is issued and the system returns the 'OK' response.

When parameters 0-7 are sent to the RF modem, the respective interface data rates are used (as shown in the table on the right).

The RF data rate is not affected by the BD parameter. If the interface data rate is set higher than the RF data rate, a flow control configuration may need to be implemented.

AT Command: ATBD

Parameter Range: 0 – 7 (standard rates)

Parameter	Configuration (bps)
0	1200
1	2400
2	4800
3	9600
4	19200
5	38400
6	57600
7	115200

Default Parameter Value:3

Non-standard Interface Data Rates:

When parameter values outside the range of standard baud rates are sent, the closest interface data rate represented by the number is stored in the BD register. For example, a rate of 19200 bps can be set by sending the following command line "ATBD4B00". NOTE: When using MaxStream's X-CTU Software, non-standard interface data rates can only be set and read using the X-CTU 'Terminal' tab. Non-standard rates are not accessible through the 'Modem Configuration' tab.

When the BD command is sent with a non-standard interface data rate, the UART will adjust to accommodate the requested interface rate. In most cases, the clock resolution will cause the stored BD parameter to vary from the parameter that was sent (refer to the table below). Reading the BD command (send "ATBD" command without an associated parameter value) will return the value that was actually stored to the BD register.

Table 3-02. Parameters Sent Versus Parameters Stored

BD Parameter Sent (HEX)	Interface Data Rate (bps)	BD Parameter Stored (HEX)
0	1200	0
4	19,200	4
7	115,200	7
12C	300	12B
1C200	115,200	1B207

CC (Command Sequence Character) Command

<AT Command Mode Options> The CC command is used to set and read the ASCII character used between guard times of the AT Command Mode Sequence (GT + CC + GT). This sequence enters the RF module into AT Command Mode so that data entering the modem from the host is recognized as commands instead of payload.

Refer to the Command Mode section [p13] for more information regarding the AT Command Mode Sequence.

AT Command: ATCC

Parameter Range: 0 – 0xFF

Default Parameter Value: 0x2B (ASCII "+")

Related Commands: GT (Guard Times)

CH (Channel) Command

<Networking {Addressing}> The CH command is used to set and read the channel on which RF connections are made between RF modules. The channel is one of three filtration layers available to the RF module. The other layers are the PAN ID (ID command) and destination addresses (DL & DH commands).

In order for RF modules to communicate with each other, the RF modules must share the same channel number. Different channels can be used to prevent RF modules in one network from listening to transmissions of another.

The RF module uses channel numbers of the 802.15.4 standard.

$$\text{Center Frequency} = 2.405 + (\text{CH} - 11d) * 5 \text{ MHz} \quad (d = \text{decimal})$$

Refer to the "Addressing" section [p9] for more information.

AT Command: ATCH

Parameter Range: 0x0B – 0x1A (XBee)
0x0C – 0x18 (XBee-PRO)

Default Parameter Value: 0x0C (12 decimal)

Related Commands: ID (PAN ID), DL (Destination Address Low, DH (Destination Address High)

CN (Exit AT Command Mode) Command

<AT Command Mode Options> The CN command is used to explicitly exit the RF module from AT Command Mode.

AT Command: ATCN

CT (Command Mode Timeout) Command

<AT Command Mode Options> The CT command is used to set and read the amount of inactive time that elapses before the RF module automatically exits from AT Command Mode and returns to Idle Mode.

Use the CN (Exit AT Command Mode) command to exit AT Command Mode manually.

AT Command: ATCT

Parameter Range: 2 – 0xFFFF
[x 100 milliseconds]

Default Parameter Value: 0x64 (100 decimal, which equals 10 decimal seconds)

Number of bytes returned: 2

Related Command: CN (Exit AT Command Mode)

DB (Received Signal Strength) Command

<Diagnostics> DB parameter is used to read the received signal strength (in dBm) of the last RF packet received. Reported values are accurate between -40 dBm and the RF module's receiver sensitivity.

Absolute values are reported. For example: 0x58 = -88 dBm (decimal). If no packets have been received (since last reset, power cycle or sleep event), "0" will be reported.

AT Command: ATDB

Parameter Range: 0 – 0x64 [read-only]

DH (Destination Address High) Command

<Networking {Addressing}> The DH command is used to set and read the upper 32 bits of the RF module's 64-bit destination address. When combined with the DL (Destination Address Low) parameter, it defines the destination address used for transmission.

An RF module will only communicate with other RF modules having the same channel (CH parameter), PAN ID (ID parameter) and destination address (DH + DL parameters).

To transmit using a 16-bit address, set the DH parameter to zero and the DL parameter less than 0xFFFF. 0x000000000000FFFF (DL concatenated to DH) is the broadcast address for the PAN.

Refer to the "Addressing" section [p9] for more information.

AT Command: ATDH

Parameter Range: 0 – 0xFFFFFFFF

Default Parameter Value: 0

Related Commands: DL (Destination Address Low), CH (Channel), ID (PAN VID), MY (Source Address)

DL (Destination Address Low) Command

<Networking {Addressing}> The DL command is used to set and read the lower 32 bits of the RF module's 64-bit destination address. When combined with the DH (Destination Address High) parameter, it defines the destination address used for transmission.

An RF module will only communicate with other RF modules having the same channel (CH parameter), PAN ID (ID parameter) and destination address (DH + DL parameters).

To transmit using a 16-bit address, set the DH parameter to zero and the DL parameter less than 0xFFFF. 0x00000000000000FFFF (DL concatenated to DH) is the broadcast address for the PAN.

Refer to the "Addressing" section [p9] for more information.

AT Command: ATDL

Parameter Range: 0 - 0xFFFFFFFF

Default Parameter Value: 0

Related Commands: DH (Destination Address High), CH (Channel), ID (PAN VID), MY (Source Address)

GT (Guard Times) Command

<AT Command Mode Options> GT Command is used to set the DI (data in from host) time-of-silence that surrounds the AT command sequence character (CC Command) of the AT Command Mode sequence (GT + CC + GT).

The DI time-of-silence is used to prevent inadvertent entrance into AT Command Mode.

Refer to the Command Mode section [p13] for more information regarding the AT Command Mode Sequence.

AT Command: ATGT

Parameter Range: 2 - 0xFFFF
[x 1 millisecond]

Default Parameter Value: 0x3E8
(1000 decimal)

Related Command: CC (Command Sequence Character)

ID (Pan ID) Command

<Networking {Addressing}> The ID command is used to set and read the PAN (Personal Area Network) ID of the RF module. Only RF modules with matching PAN IDs can communicate with each other. RF modems with non-matching PAN IDs will not receive unintended data transmission.

Setting the ID parameter to 0xFFFF indicates a global message for all PANs.

Refer to the "Addressing" section [p9] for more information.

AT Command: ATID

Parameter Range: 0 - 0xFFFF

Default Parameter Value: 0x3332
(13106 decimal)

MY (16-bit Source Address) Command

<Networking {Addressing}> The MY command is used to set and read the 16-bit source address of the RF module.

By setting MY to 0xFFFF, the reception of RF packets having a 16-bit address is disabled. The 64-bit address is the module serial number and is always enabled.

Refer to the "Addressing" section [p9] for more information.

AT Command: ATMY

Parameter Range: 0 - 0xFFFF

Default Parameter Value: 0

Related Commands: DH (Destination Address High), DL (Destination Address Low), CH (Channel), ID (PAN ID)

P0 (PWM0 Configuration) Command

<Diagnostics> The P0 command is used to select and read the function for PWM0 (Pulse Width Modulation output 0 - pin 6).

Note: The second character in the command is a zero ("0"), not the letter "O".

AT Command: ATP0

Parameter Range: 0 – 1

Parameter	Configuration
0	Disabled
1	RSSI PWM0 enabled

Default Parameter Value: 1

PL (Power Level) Command

<RF Interfacing> The PL command is used to select and read the power level at which the RF module transmits conducted power.

WHEN OPERATING IN EUROPE:

XBee-PRO Modules must be configured to operate at a maximum transmit power output level of 10 dBm. The PL parameter must equal "0" (10 dBm).

Additionally, European regulations stipulate an EIRP power maximum of 12.86 dBm (19 mW) for the XBee-PRO and 12.11 dBm for the XBee when integrating high-gain antennas.

AT Command: ATPL

Parameter Range: 0 – 4

Parameter	XBee	XBee-Pro
0	-10 dBm	10 dBm
1	-6 dBm	12 dBm
2	-4 dBm	14 dBm
3	-2 dBm	16 dBm
4	0 dBm	18 dBm

Default Parameter Value: 4

RE (Restore Defaults) Command

<(Special)> The RE command is used to restore all configurable parameters to their factory default settings. The RE command does not write restored values to non-volatile (persistent) memory. Issue the WR (Write) command subsequent to issuing the RE command to save restored parameter values to non-volatile memory.

AT Command: ATRE

RN (Random Delay Slots) Command

<Networking & Security> The RN command is used to set and read the minimum value of the back-off exponent in the CSMA-CA algorithm. The CSMA-CA algorithm was engineered for collision avoidance (random delays are inserted to prevent data loss caused by data collisions).

If RN = 0, collision avoidance is disabled during the first iteration of the algorithm (802.15.4 - macMinBE).

CSMA-CA stands for "Carrier Sense Multiple Access - Collision Avoidance". Unlike CSMA-CD (reacts to network transmissions after collisions have been detected), CSMA-CA acts to prevent data collisions before they occur. As soon as a modem receives a packet that is to be transmitted, it checks if the channel is clear (no other modem is transmitting). If the channel is clear, the packet is sent over-the-air. If the channel is not clear, the RF module waits for a randomly selected period of time, then checks again to see if the channel is clear. After a time, the process ends and the data is lost.

AT Command: ATRN

Parameter Range: 0 – 3 [exponent]

Default Parameter Value: 0

RO (Packetization Timeout) Command

<Serial Interfacing> RO command is used to set and read the number of character times of inter-character delay required before transmission.

RF transmission commences when data is detected in the DI (data in from host) buffer and RO character times of silence are detected on the UART receive lines (after receiving at least 1 byte).

RF transmission will also commence after 100 bytes (maximum packet size) are received in the DI buffer.

Set the RO parameter to '0' to transmit characters as they arrive instead of buffering them into one RF packet.

AT Command: ATRO

Parameter Range: 0 – 0xFF
[x character times]

Default Parameter Value: 3

RP (RSSI PWM Timer) Command

<Diagnostics> The RP command is used to enable PWM (Pulse Width Modulation) output on the RF module. The output is calibrated to show the level a received RF signal is above the sensitivity level of the RF module. The PWM pulses vary from zero to 95 percent. Zero to twenty-nine percent means the received RF signal is at or below the published sensitivity level of the RF module. The following table shows levels above sensitivity and PWM values.

The total period of the PWM output is 8.32 ms. Because there are 40 steps in the PWM output, the minimum step size is 0.208 ms.

Table 3-03. PWM Percentages

dB above Sensitivity	PWM percentage* (high period / total period)
10	46.0%
20	63.0%
30	80.1%

* PWM% = (295 + (17.5 * dBm above sensitivity)) / 10.24

A non-zero value defines the time that the PWM output will be active with the RSSI value of the last received RF packet. After the set time when no RF packets are received, the PWM output will be set low (0 percent PWM) until another RF packet is received. The PWM output will also be set low at power-up until the first RF packet is received. A parameter value of 0xFF permanently enables the PWM output and it will always reflect the value of the last received RF packet.

AT Command: ATRP

Parameter Range: 0 – 0xFF
[x 100 milliseconds]

Default Parameter Value: 0x28 (40 decimal)

SH (Serial Number High) Command

<Diagnostics> The SH command is used to read the high 32 bits of the RF module's unique IEEE 64-bit address.

The RF module serial number is set at the factory and is read-only.

AT Command: ATSH

Parameter Range: 0 – 0xFFFFFFFF [read-only]

Related Commands: SL (Serial Number Low), MY (Source Address)

SL (Serial Number Low) Command

<Diagnostics> The SL command is used to read the low 32 bits of the RF module's unique IEEE 64-bit address.

The RF module serial number is set at the factory and is read-only.

AT Command: ATSL

Parameter Range: 0 – 0xFFFFFFFF [read-only]

Related Commands: SH (Serial Number High), MY (Source Address)

SM (Sleep Mode) Command

<Sleep Mode (Low Power)> The SM command is used to set and read Sleep Mode settings. By default, Sleep Modes are disabled (SM = 0) and the RF module remains in Idle/Receive Mode. When in this state, the RF module is constantly ready to respond to either serial or RF activity.

AT Command: ATSM

Parameter Range: 0 – 6

Parameter	Configuration
0	Disabled
1	Pin Hibernate
2	Pin Doze
3	(reserved)
4	Cyclic Sleep Remote
5	Cyclic Sleep Remote (with Pin Wake-up)
6	Cyclic Sleep Coordinator

Default Parameter Value: 0

Related Commands: SP (Cyclic Sleep Period), ST (Time before Sleep)

SP (Cyclic Sleep Period) Command

<Sleep Mode (Low Power)> The SP command is used to set and read the duration of time in which a remote RF module sleeps. After the cyclic sleep period is over, the RF module wakes and checks for data. If data is not present, the RF module goes back to sleep. The maximum sleep period is 268 seconds (SP = 0x68B0).

AT Command: ATSP

Parameter Range: 1 – 0x68B0
[x 10 milliseconds]

Default Parameter Value: 0x64 (100d)

Related Commands: SM (Sleep Mode), ST (Time before Sleep)

SP parameter is only valid if the RF module is configured to operate in Cyclic Sleep (SM = 4-6).

ST (Time before Sleep) Command

<Sleep Mode (Low Power)> The ST command is used to set and read the period of time that the RF module remains inactive (no transmitting or receiving) before entering into Sleep Mode.

AT Command: ATST

Parameter Range: 1 – 0xFFFF
[x 1 millisecond]

Default Parameter Value: 0x1388
(5000 decimal)

Related Commands: SM (Sleep Mode), SP (Cyclic Sleep Period)

For example, if the ST parameter is set to its default value of 0x1388 (5000 decimal), the RF module will enter into Sleep mode after 5 seconds of inactivity. This command can only be used if Cyclic Sleep settings have been selected using SM (Sleep Mode) Command (SM = 4-6).

VR (Firmware Version) Command

<Diagnostics> The VR command is used to read firmware version stored in the RF module.

AT Command: ATVR

Parameter Range: 0 – 0xFFFF [read only]

WR (Write) Command

<(Special)> The WR command is used to write configurable parameters to the RF module's non-volatile memory (Parameter values remain in RF module's memory until overwritten by subsequent use of the WR Command).

AT Command: ATWR

If changes are made without writing them to non-volatile memory, the RF module reverts back to previously saved parameters the next time the RF module is powered-on.

NOTE: Once the WR command is sent to the RF module, no additional characters should be sent until after the "OK/r" response is received.

Appendix A: Agency Certifications

FCC Certification

The XBee/XBee-PRO RF Module complies with Part 15 of the FCC rules and regulations. Compliance with the labeling requirements, FCC notices and antenna usage guidelines is required.

To fulfill FCC Certification requirements, the OEM must comply with the following regulations:

1. The system integrator must ensure that the text on the external label provided with this device is placed on the outside of the final product [Figure A-01].
2. The XBee/XBee-PRO RF Module may be used only with approved antennas that have been tested with this modem.

OEM Labeling Requirements



WARNING: The Original Equipment Manufacturer (OEM) must ensure that FCC labeling requirements are met. This includes a clearly visible label on the outside of the final product enclosure that displays the contents shown in the figure below.

Figure A-01. Required FCC Label for OEM products containing the XBee/XBee-PRO RF Module

Contains FCC ID: OUR-XBEE / OUR-XBEEPRO*

The enclosed device complies with Part 15 of the FCC Rules. Operation is subject to the following two conditions: (1) this device may not cause harmful interference and (2) this device must accept any interference received, including interference that may cause undesired operation.

* The FCC ID for the XBee is "OUR-XBEE". The FCC ID for the XBee-PRO is "OUR-XBEEPRO".

FCC Notices

IMPORTANT: The XBee/XBee-PRO OEM RF Module has been certified by the FCC for use with other products without any further certification (as per FCC section 2.1091). Modifications not expressly approved by MaxStream could void the user's authority to operate the equipment.

IMPORTANT: OEMs must test final product to comply with unintentional radiators (FCC section 15.107 & 15.109) before declaring compliance of their final product to Part 15 of the FCC Rules.

IMPORTANT: The RF module has been certified for remote and base radio applications. If the module will be used for portable applications, the device must undergo SAR testing.

This equipment has been tested and found to comply with the limits for a Class B digital device, pursuant to Part 15 of the FCC Rules. These limits are designed to provide reasonable protection against harmful interference in a residential installation. This equipment generates, uses and can radiate radio frequency energy and, if not installed and used in accordance with the instructions, may cause harmful interference to radio communications. However, there is no guarantee that interference will not occur in a particular installation.

If this equipment does cause harmful interference to radio or television reception, which can be determined by turning the equipment off and on, the user is encouraged to try to correct the interference by one or more of the following measures: Re-orient or relocate the receiving antenna, Increase the separation between the equipment and receiver, Connect equipment and receiver to outlets on different circuits, or Consult the dealer or an experienced radio/TV technician for help.

FCC-Approved Antennas (2.4 GHz)

The XBee/XBee-Pro OEM RF Module can be installed utilizing antennas and cables constructed with standard connectors (Type-N, SMA, TNC, etc.) if the installation is performed professionally and according to FCC guidelines. For installations not performed by a professional, non-standard connectors (RPSMA, RPTNC, etc.) must be used.

The modules are pre-FCC approved for use in fixed base station and mobile applications [refer to table below]. As long as the antenna is mounted at least 20 cm (8 in) from nearby persons, the application is considered a mobile application. Antennas not listed in the table must be tested to comply with FCC Section 15.203 (unique antenna connectors) and Section 15.247 (emissions).

Table A-01. Antennas approved for use with the XBee/XBee-PRO OEM RF Modules (all 2.4 GHz)

Part Number	Type (Description)	Gain	Application	Min. Separation
A24-HABMM-PSI	Dipole (Half-wave bulkhead mount articulated MMCX w/ pigtail)	2.1 dBi	Fixed/Mobile*	20 cm
A24-HBMM-PSI	Dipole (Half-wave bulkhead mount MMCX w/ pigtail)	2.1 dBi	Fixed/Mobile*	20 cm
A24-HABSM	Dipole (Articulated RPSMA)	2.1 dBi	Fixed/Mobile*	20 cm
A24-QBMM-PSI	Monopole (Quarter-wave bulkhead mount MMCX w/pigtail)	1.9 dBi	Fixed/Mobile*	20 cm
A24-QABMM-PSI	Monopole (Quarter-wave bulkhead mount articulated MMCX w/pigtail)	1.9 dBi	Fixed/Mobile*	20 cm
A24-QI	Monopole (Integrated whip)	1.9 dBi	Fixed/Mobile*	20 cm
A24-C1	Surface Mount	-1.5 dBi	Fixed/Mobile*	20 cm
A24-Y4NF	Yagi (4-element)	6.0 dBi	Fixed*	2 m
A24-Y6NF	Yagi (6-element)	8.8 dBi	Fixed*	2 m
A24-Y7NF	Yagi (7-element)	9.0 dBi	Fixed*	2 m
A24-Y9NF	Yagi (9-element)	10.0 dBi	Fixed*	2 m
A24-Y10NF	Yagi (10-element)	11.0 dBi	Fixed*	2 m
A24-Y12NF	Yagi (12-element)	12.0 dBi	Fixed*	2 m
A24-Y13NF	Yagi (13-element)	12.0 dBi	Fixed*	2 m
A24-Y15NF	Yagi (15-element)	12.5 dBi	Fixed*	2 m
A24-Y16NF	Yagi (16-element)	13.5 dBi	Fixed*	2 m
A24-Y16RM	Yagi (16-element, RPSMA connector)	13.5 dBi	Fixed*	2 m
A24-Y18NF	Yagi (18-element)	15.0 dBi	Fixed*	2 m
A24-F2NF	Omni-directional (Fiberglass base station)	2.1 dBi	Fixed/Mobile*	20 cm
A24-F3NF	Omni-directional (Fiberglass base station)	3.0 dBi	Fixed/Mobile*	20 cm
A24-F5NF	Omni-directional (Fiberglass base station)	5.0 dBi	Fixed/Mobile*	20 cm
A24-F8NF	Omni-directional (Fiberglass base station)	8.0 dBi	Fixed*	2 m
A24-F9NF	Omni-directional (Fiberglass base station)	9.5 dBi	Fixed*	2 m
A24-F10NF	Omni-directional (Fiberglass base station)	10.0 dBi	Fixed*	2 m
A24-F12NF	Omni-directional (Fiberglass base station)	12.0 dBi	Fixed*	2 m
A24-F15NF	Omni-directional (Fiberglass base station)	15.0 dBi	Fixed*	2 m
A24-W7NF	Omni-directional (Base station)	7.2 dBi	Fixed*	2 m
A24-M7NF	Omni-directional (Mag-mount base station)	7.2 dBi	Fixed*	2 m
A24-P8SF	Flat Panel	8.5 dBi	Fixed*	2 m
A24-P8NF	Flat Panel	8.5 dBi	Fixed*	2 m
A24-P13NF	Flat Panel	13.0 dBi	Fixed*	2 m
A24-P14NF	Flat Panel	14.0 dBi	Fixed*	2 m
A24-P15NF	Flat Panel	15.0 dBi	Fixed*	2 m
A24-P16NF	Flat Panel	16.0 dBi	Fixed*	2 m
A24-P19NF	Flat Panel	19.0 dBi	Fixed*	2 m

* If used in a portable application, such as a handheld device with the antenna less than 20cm from the human body when the device is operating, the integrator is responsible for passing additional SAR (Specific Absorption Rate) testing based on FCC rules 2.1091 and FCC Guidelines for Human Exposure to Radio Frequency Electromagnetic Fields, OET Bulletin and Supplement C. The testing results will be submitted to the FCC for approval prior to selling the integrated unit. The required SAR testing measures emissions from the module and how they affect the person.

RF Exposure



WARNING: To satisfy FCC RF exposure requirements for mobile transmitting devices, a separation distance of 20 cm or more should be maintained between the antenna of this device and persons during device operation. To ensure compliance, operations at closer than this distance is not recommended. The antenna used for this transmitter must not be co-located in conjunction with any other antenna or transmitter.

The preceding statement must be included as a CAUTION statement in manuals for OEM products to alert users on FCC RF Exposure compliance.

European Certification

The XBee/XBee-PRO RF Module has been certified for use in several European countries. For a complete list, refer to www.maxstream.net.

If the XBee/XBee-PRO RF Modules are incorporated into a product, the manufacturer must ensure compliance of the final product to the European harmonized EMC and low-voltage/safety standards. A Declaration of Conformity must be issued for each of these standards and kept on file as described in Annex II of the R&TTE Directive. Furthermore, the manufacturer must maintain a copy of the XBee/XBee-PRO user manual documentation and ensure the final product does not exceed the specified power ratings, antenna specifications, and/or installation requirements as specified in the user manual. If any of these specifications are exceeded in the final product, a submission must be made to a notified body for compliance testing to all required standards.

OEM Labeling Requirements

The 'CE' marking must be affixed to a visible location on the OEM product.

Figure A-02. CE Labeling Requirements

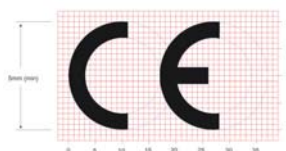

The CE mark shall consist of the initials "CE" taking the following form:

- If the CE marking is reduced or enlarged, the proportions given in the above graduated drawing must be respected.
- The CE marking must have a height of at least 5mm except where this is not possible on account of the nature of the apparatus.
- The CE marking must be affixed visibly, legibly, and indelibly.

Restrictions

Power Output: The power output of the XBee-PRO RF Modules must not exceed 10 dBm. The power level is set using the PL command. The PL parameter must equal "0" (10 dBm).

Additionally, European regulations stipulate an EIRP power maximum of 12.86 dBm (19 mW) for the XBee-PRO and 12.11 dBm for the XBee (not applicable to the XBee-PRO RS-232 and USB RF Modems) when integrating high-gain antennas.

France: France imposes restrictions on the 2.4 GHz band. Go to www.art-telecom.fr or contact MaxStream for more information.

Norway: Norway prohibits operation near Ny-Alesund in Svalbard. More information can be found at the Norway Posts and Telecommunications site (www.npt.no).

Declarations of Conformity

MaxStream has issued Declarations of Conformity for the XBee/XBee-PRO RF Modules concerning emissions, EMC and safety. Files are located in the 'documentation' folder of the MaxStream CD.

Important Note

MaxStream does not list the entire set of standards that must be met for each country. MaxStream customers assume full responsibility for learning and meeting the required guidelines for each country in their distribution market. For more information relating to European compliance of an OEM product incorporating the XBee/XBee-PRO RF Module, contact MaxStream, or refer to the following web sites:

CEPT ERC 70-03E - Technical Requirements, European restrictions and general requirements: Available at www.ero.dk/.

R&TTE Directive - Equipment requirements, placement on market: Available at www.ero.dk/.

Appendix B: Development Guide

Development Kit Contents

The XBee Development Kit includes the hardware and software needed to rapidly create long range wireless links between devices.

Table B-01. Items Included in the Development Kit

Item	Qty.	Description	Part #
XBee-PRO Module	2	(1) OEM RF Module w/ U.FL antenna connector (1) OEM RF Module w/ attached wire antenna	XBP24-...UI-... XBP24-...WI-...
XBee Module	3	(1) OEM RF Module w/ U.FL antenna connector (1) OEM RF Module w/ attached wire antenna (1) OEM RF Module w/ chip antenna	XB24-...UI-... XB24-...WI-... XB24-...CI-...
RS-232 Interface Board	1	Board for interfacing between modules and RS-232 devices (Converts signal levels, displays diagnostic info, & more)	XBIB-R
USB Interface Board	1	Board for interfacing between modules & USB devices (Converts signal levels, displays diagnostic info, & more)	XBIB-U
RS-232 Cable (6', straight-through)	1	Cable for connecting RS-232 interface board with DTE devices (devices that have a male serial DB-9 port - such as most PCs)	JD2D3-CDS-6F
USB Cable (6')	1	Cable for connecting USB interface board to USB devices	JU1U2-CSB-6F
Serial Loopback Adapter	1	[Red] Adapter for configuring the module assembly (module + RS-232 interface board) to function as a repeater for range testing	JD2D3-CDL-A
NULL Modem Adapter (male-to-male)	1	[Black] Adapter for connecting the module assembly (module + RS-232 interface board) to other DCE (female DB-9) devices	JD2D2-CDN-A
NULL Modem Adapter (female-to-female)	1	[Gray] Adapter for connecting serial devices. It allows users to bypass the radios to verify serial cabling is functioning properly.	JD3D3-CDN-A
9VDC Power Adapter	1	Adapter for powering the RS-232 interface board	JP5P2-9V11-6F
9V Battery Clip	1	Clip for remotely powering the RS-232 board w/ a 9V battery	JP2P3-C2C-4I
RPSMA Antenna	1	RPSMA half-wave dipole antenna (2.4 GHz, 2.1 dB)	A24-HASM-525
RF Cable Assembly	1	Adapter for connecting RPSMA antenna to U.FL connector	JF1R6-CR3-4I
CD	1	Documentation and Software	MD0010
Quick Start Guide	1	Step-by-step instruction on how to create wireless links & test range capabilities of the modules	MD0026

Interfacing Options

The development kit includes an RS-232 and a USB interface board. Both boards provide a direct connection to many serial devices and therefore provide access to the RF module registries. Parameters stored in the registry allow OEMs and integrators to customize the modules to suite the needs of their data radio systems.

The following sections illustrate how to use the interface boards for development purposes. The MaxStream Interface board provides means for connecting the module to any node that has an available RS-232 or USB connector. Since the module requires signals to enter at TTL voltages, one of the main functions of the interface board is to convert signals between TTL levels and RS-232 and USB levels.

Note: In the following sections, an OEM RF Module mounted to an interface board will be referred to as a "Module Assembly".

RS-232 Interface Board

Physical Interface

Figure B-01. Front View

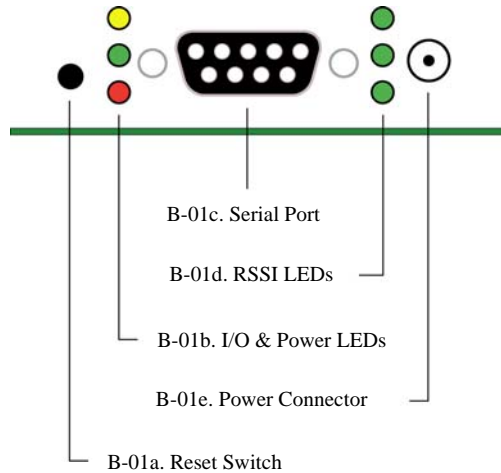

B-01a. Reset Switch

The Reset Switch is used to reset (re-boot) the RF module. This switch only applies when using the configuration tabs of MaxStream's X-CTU Software.

B-01b. I/O & Power LEDs

LEDs indicate RF module activity as follows:

- Yellow (top LED) = Serial Data Out (to host)
- Green (middle) = Serial Data In (from host)
- Red (bottom) = Power/TX Indicator (LED is on when module assembly is powered)



B-01c. Serial Port

Standard female DB-9 (RS-232) connector.

B-01d. RSSI LEDs

RSSI LEDs indicate the amount of fade margin present in an active wireless link. Fade margin is defined as the difference between the incoming signal strength and the modem's receiver sensitivity.

- 3 LEDs ON = Very Strong Signal (> 30 dB fade margin)
- 2 LEDs ON = Strong Signal (> 20 dB fade margin)
- 1 LED ON = Moderate Signal (> 10 dB fade margin)
- 0 LED ON = Weak Signal (< 10 dB fade margin)

B-01e. Power Connector

5-14 VDC power connector

Figure B-02. Back View

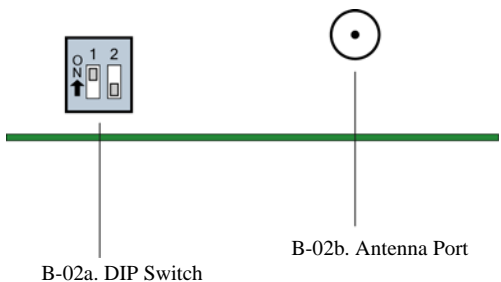

B-02a. DIP Switch

DIP Switch functions are not supported in this release. Future downloadable firmware versions will support DIP Switch configurations.

B-02b. Antenna Port

Port is a 50Ω RF signal connector for connecting to an external antenna. The connector type is RPSMA (Reverse Polarity SMA) female. The connector has threads on the outside of a barrel and a male center conductor.

RS-232 Pin Signals

Figure B-03. Pins used on the female RS-232 (DB-9) Serial Connector

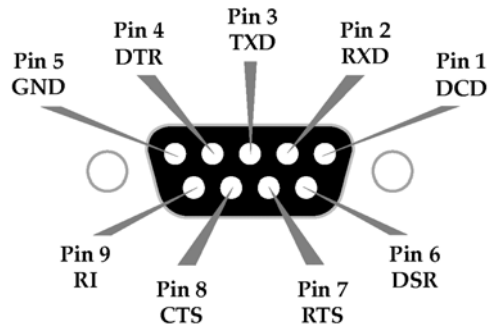

Table B-02. Pin Assignments and Implementations

DB-9 Pin	RS-232 Name	Description	Implementation*
1	DCD	Data-Carrier-Detect	Connected to DSR (pin6)
2	RXD	Received Data	Serial data exiting the module assembly (to host)
3	TXD	Transmitted Data	Serial data entering into the module assembly (from host)
4	DTR	Data-Terminal-Ready	Can enable Power-Down on the module assembly
5	GND	Ground Signal	Ground
6	DSR	Data-Set-Ready	Connected to DCD (pin1)
7	$\overline{\text{RTS}}$ / CMD	Request-to-Send / Command Mode	Provides $\overline{\text{RTS}}$ flow control or enables Command Mode
8	$\overline{\text{CTS}}$	Clear-to-Send	Provides $\overline{\text{CTS}}$ flow control
9	RI	Ring Indicator	Optional power input that is connected internally to the positive lead of the front power connector

* Functions listed in the implementation column may not be available at the time of release.

Wiring Diagrams

Figure B-04. DTE Device (RS-232, male DB-9 connector) wired to a DCE Module Assembly (female DB-9)

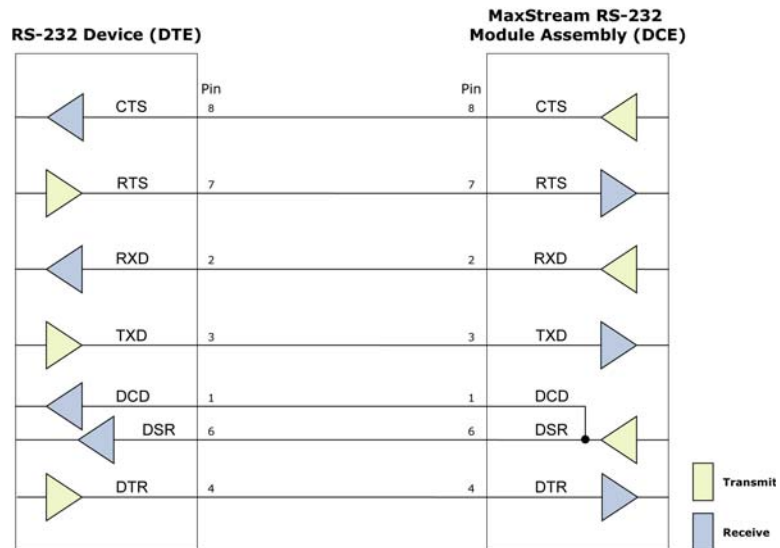
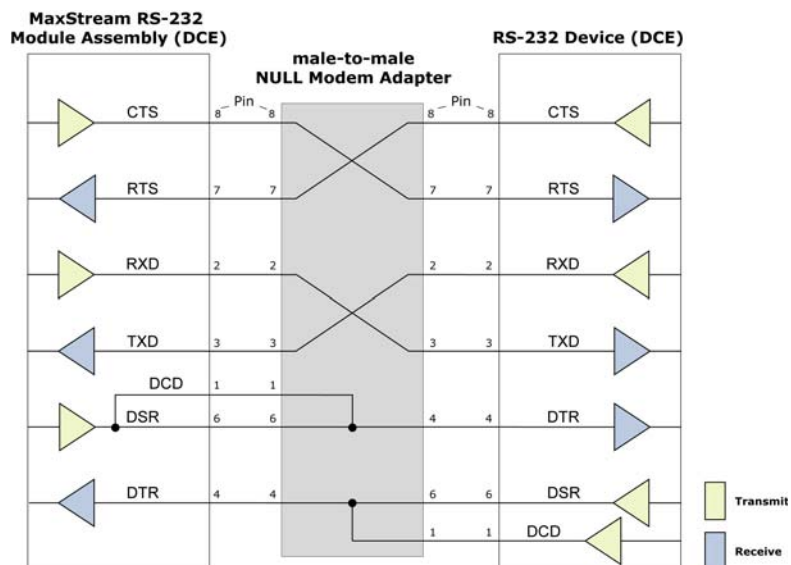
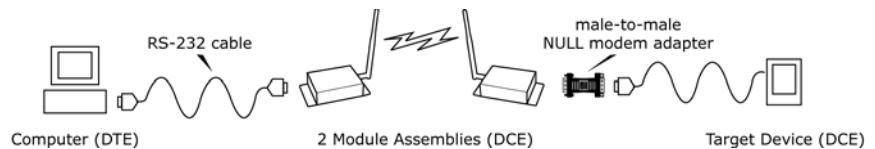

Figure B-05. DCE Module Assembly (female DB-9 connector) wired to a DCE Device (RS-232, male DB-9)



Sample Wireless Connection: DTE <--> DCE <--> DCE <--> DCE

Figure B-06. Typical wireless link between DTE and DCE devices



Adapters

The development kit includes several adapters that support the following functions:

- Performing Range Tests
- Testing Cables
- Connecting to other RS-232 DCE and DTE devices
- Connecting to terminal blocks or RJ-45 (for RS-485/422 devices)

NULL Modem Adapter (male-to-male)

Part Number: JD2D2-CDN-A (Black, DB-9 M-M) The male-to-male NULL modem adapter is used to connect two DCE devices. A DCE device connects with a straight-through cable to the male serial port of a computer (DTE).

Figure B-07. Male NULL modem adapter and pinouts

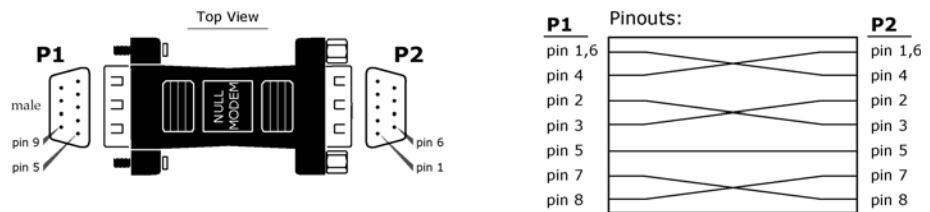
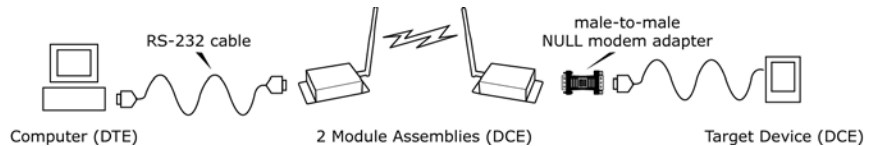

Figure B-08. Example of a MaxStream Radio Modem (DCE Device) connecting to another DCE device



NULL Modem Adapter (female-to-female)

Part Number: JD3D3-CDN-A (Gray, DB-9 F-F) The female-to-female NULL modem adapter is used to verify serial cabling is functioning properly. To test cables, insert the female-to-female NULL modem adapter in place of a pair of module assemblies (RS-232 interface board + XTend Module) and test the connection without radio modules in the connection.

Figure B-09. Female NULL modem adapter and pinouts

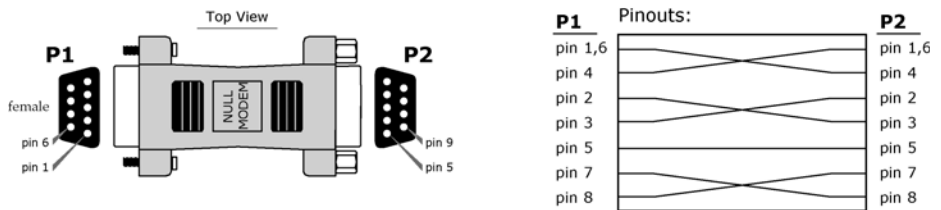

Serial Loopback Adapter

Part Number: JD2D3-CDL-A (Red, DB-9 M-F) The serial loopback adapter is used for range testing. During a range test, the serial loopback adapter configures the module to function as a repeater by looping serial data back into the radio for retransmission.

Figure B-10. Serial loopback adapter and pinouts

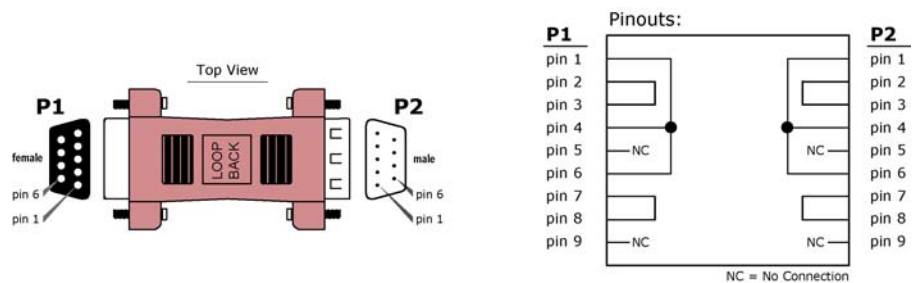

USB Interface Board

Physical Interface

B-11a. I/O & Power LEDs

Figure B-11. Front View

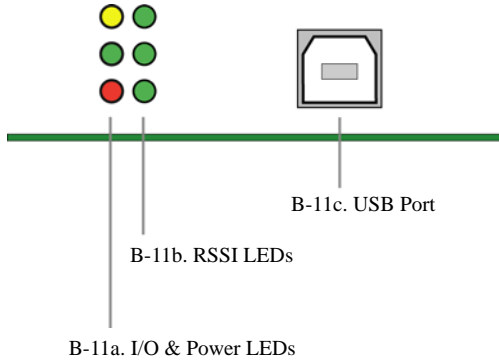

LEDs indicate RF module activity as follows:

- Yellow (top LED) = Serial Data Out (to host)
- Green (middle) = Serial Data In (from host)
- Red (bottom) = Power/TX Indicator (Red LED is illuminated when RF module is powered)



B-11b. RSSI LEDs

RSSI LEDs indicate the amount of fade margin present in an active wireless link. Fade margin is defined as the difference between the incoming signal strength and the module's receiver sensitivity.

- 3 LEDs ON = Very Strong Signal (> 30 dB fade margin)
- 2 LEDs ON = Strong Signal (> 20 dB fade margin)
- 1 LED ON = Moderate Signal (> 10 dB fade margin)
- 0 LED ON = Weak Signal (< 10 dB fade margin)

B-11c. USB Port

Standard Type-B OEM connector is used to communicate with OEM host and power the RF module.

B-12a. DIP Switch

Figure B-12. Back View

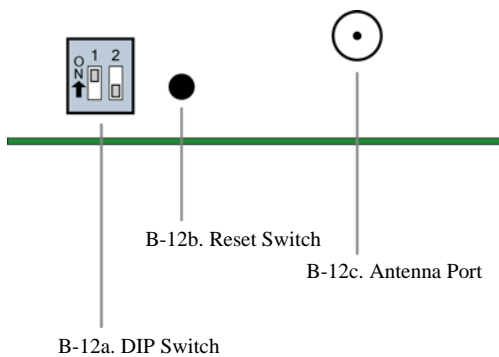

DIP Switch functions are not supported in this release. Future downloadable firmware versions will support the DIP Switch configurations.

B-12b Reset Switch

The Reset Switch is used to reset (re-boot) the RF module.

B-12c. Antenna Port

Port is a 50Ω RF signal connector for connecting to an external antenna. The connector type is RPSMA (Reverse Polarity SMA) female. The connector has threads on the outside of a barrel and a male center conductor.

USB Pin Signals

Table B-03. USB signals and their implantations on the XBee/XBee-PRO RF Module

Pin	Name	Description	Implementation
1	VBUS	Power	Power the RF module
2	D-	Transmitted & Received Data	Transmit data to and from the RF module
3	D+	Transmitted & Received Data	Transmit data to and from the RF module
4	GND	Ground Signal	Ground

Appendix C: Additional Information

1-Year Warranty

XBee/XBee-PRO RF Modules from MaxStream, Inc. (the "Product") are warranted against defects in materials and workmanship under normal use, for a period of 1-year from the date of purchase. In the event of a product failure due to materials or workmanship, MaxStream will repair or replace the defective product. For warranty service, return the defective product to MaxStream, shipping prepaid, for prompt repair or replacement.

The foregoing sets forth the full extent of MaxStream's warranties regarding the Product. Repair or replacement at MaxStream's option is the exclusive remedy. THIS WARRANTY IS GIVEN IN LIEU OF ALL OTHER WARRANTIES, EXPRESS OR IMPLIED, AND MAXSTREAM SPECIFICALLY DISCLAIMS ALL WARRANTIES OF MERCHANTABILITY OR FITNESS FOR A PARTICULAR PURPOSE. IN NO EVENT SHALL MAXSTREAM, ITS SUPPLIERS OR LICENSORS BE LIABLE FOR DAMAGES IN EXCESS OF THE PURCHASE PRICE OF THE PRODUCT, FOR ANY LOSS OF USE, LOSS OF TIME, INCONVENIENCE, COMMERCIAL LOSS, LOST PROFITS OR SAVINGS, OR OTHER INCIDENTAL, SPECIAL OR CONSEQUENTIAL DAMAGES ARISING OUT OF THE USE OR INABILITY TO USE THE PRODUCT, TO THE FULL EXTENT SUCH MAY BE DISCLAIMED BY LAW. SOME STATES DO NOT ALLOW THE EXCLUSION OR LIMITATION OF INCIDENTAL OR CONSEQUENTIAL DAMAGES. THEREFORE, THE FOREGOING EXCLUSIONS MAY NOT APPLY IN ALL CASES. This warranty provides specific legal rights. Other rights which vary from state to state may also apply.

Ordering Information

Figure C-01. Divisions of the XBee/XBee-PRO RF Module Part Numbers

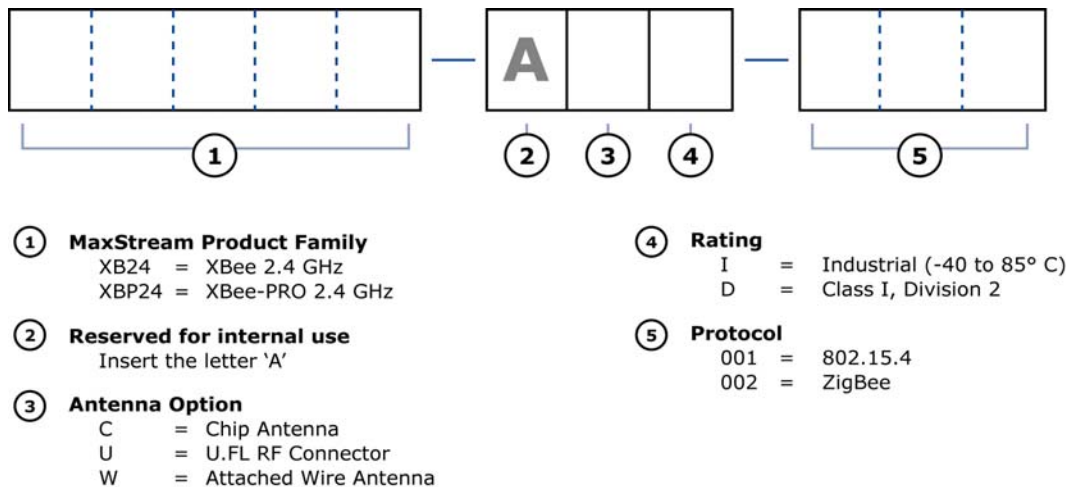

For example:

XBP24-AWI-001 = XBee-PRO OEM RF Module, 2.4 GHz, attached wire antenna, Industrial temperature rating, IEEE 802.15.4 standard

